

**TUNG-SOL**

**DOUBLE TRIODE**

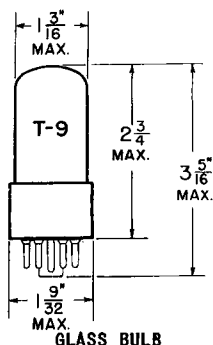

COATED UNIPOTENTIAL CATHODE

HEATER

8.4 VOLTS 0.45 AMP.

AC OR DC

ANY MOUNTING POSITION

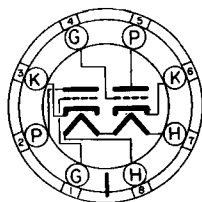

**BOTTOM VIEW**

INTERMEDIATE SHELL  
8 PIN OCTAL

BBD

THE 8SN7GTB IS A MEDIUM-MU TRIODE INTENDED FOR USE AS A COMBINED VERTICAL OSCILLATOR AND VERTICAL DEFLECTION AMPLIFIER IN 450 MA. SERIES HEATER OPERATED TELEVISION RECEIVERS. THERMAL CHARACTERISTICS OF THE HEATER ARE CONTROLLED SUCH THAT HEATER VOLTAGE SURGES DURING THE WARM-UP CYCLE ARE MINIMIZED PROVIDED IT IS USED WITH OTHER TYPES WHICH ARE SIMILARLY CONTROLLED.

**DIRECT INTERELECTRODE CAPACITANCES**

	TRIODE 1	TRIODE 2	
GRID TO PLATE: G TO P	4.0	3.8	$\mu\text{mf}$
INPUT: G TO (H+K)	2.2	2.6	$\mu\text{mf}$
OUTPUT: P TO (H+K)	0.7	0.7	$\mu\text{mf}$

**RATINGS**

INTERPRETED ACCORDING TO DESIGN CENTER SYSTEM

EACH UNIT

	CLASS A <sub>1</sub> AMPLIFIER	VERTICAL <sup>A</sup> DEFLECTION AMPLIFIER	
HEATER VOLTAGE	8.4		VOLTS
MAXIMUM HEATER-CATHODE VOLTAGE:			
HEATER NEGATIVE WITH RESPECT TO CATHODE			
TOTAL DC AND PEAK	200		VOLTS
HEATER POSITIVE WITH RESPECT TO CATHODE			
DC	100		VOLTS
TOTAL DC AND PEAK	200		VOLTS
MAXIMUM PLATE VOLTAGE	450	450	VOLTS
MAXIMUM PEAK POSITIVE PLATE VOLTAGE (ABSOLUTE MAXIMUM)	---	1 500	VOLTS
MAXIMUM PLATE DISSIPATION:			
EACH PLATE	5.0	5.0 <sup>B</sup>	WATTS
BOTH PLATES	7.5	7.5 <sup>B</sup>	WATTS
MAXIMUM PEAK NEGATIVE GRID VOLTAGE	---	250	VOLTS
MAXIMUM AVERAGE CATHODE CURRENT	20	20	MA.
MAXIMUM PEAK CATHODE CURRENT	---	7.0	MA.
MAXIMUM GRID CIRCUIT RESISTANCE (CATHODE BIAS)	1.0	2.2	MEG OHMS
HEATER WARM-UP TIME (APPROX.)*	11.0		SECONDS

<sup>A</sup> FOR OPERATION IN A 525-LINE, 30-FRAME SYSTEM AS DESCRIBED IN "STANDARDS OF GOOD ENGINEERING PRACTICE FOR TELEVISION BROADCASTING STATIONS; FEDERAL COMMUNICATIONS COMMISSION. THE DUTY CYCLE OF THE VOLTAGE PULSE NOT TO EXCEED 15% OF A SCANNING CYCLE.

<sup>B</sup> IN STAGES OPERATING WITH GRID-LEAK BIAS, AN ADEQUATE CATHODE BIAS RESISTOR OR OTHER SUITABLE MEANS IS REQUIRED TO PROTECT THE TUBE IN THE ABSENCE OF EXCITATION.

\* HEATER WARM-UP TIME IS DEFINED AS THE TIME REQUIRED FOR THE VOLTAGE ACROSS THE HEATER TO REACH 80% OF ITS RATED VOLTAGE AFTER APPLYING 4 TIMES RATED HEATER VOLTAGE TO A CIRCUIT CONSISTING OF THE TUBE HEATER IN SERIES WITH A RESISTANCE OF VALUE 3 TIMES THE NOMINAL HEATER OPERATING RESISTANCE.

CONTINUED ON FOLLOWING PAGE

## TUNG-SOL

CONTINUED FROM PRECEDING PAGE

## RATINGS - CONT'D

	VERTICAL DEFLECTION OSCILLATOR <sup>C</sup>	HORIZONTAL DEFLECTION OSCILLATOR <sup>C</sup>	
HEATER VOLTAGE		8.4	VOLTS
MAXIMUM HEATER-CATHODE VOLTAGE:			
HEATER NEGATIVE WITH RESPECT TO CATHODE			
TOTAL DC AND PEAK	200		VOLTS
HEATER POSITIVE WITH RESPECT TO CATHODE			
DC	100		VOLTS
TOTAL DC AND PEAK	200		VOLTS
MAXIMUM DC PLATE VOLTAGE	450	450	VOLTS
MAXIMUM PLATE DISSIPATION:			
EACH PLATE	5.0	5.0	WATTS
BOTH PLATES	7.5	7.5	WATTS
MAXIMUM PEAK NEGATIVE GRID VOLTAGE	400	600	VOLTS
MAXIMUM AVERAGE CATHODE CURRENT	20	20	MA.
MAXIMUM PEAK CATHODE CURRENT	70	300	MA.
MAXIMUM GRID CIRCUIT RESISTANCE	2.2	2.2	MEG OHMS
HEATER WARM-UP TIME (APPROX.)*		11.0	SECONDS

<sup>C</sup> FOR OPERATION IN A 525-LINE, 30-FRAME SYSTEM AS DESCRIBED IN "STANDARDS OF GOOD ENGINEERING PRACTICE FOR TELEVISION BROADCASTING STATIONS," FEDERAL COMMUNICATIONS COMMISSION. THE DUTY CYCLE OF THE VOLTAGE PULSE NOT TO EXCEED 15% OF A SCANNING CYCLE.

\* HEATER WARM-UP TIME IS DEFINED AS THE TIME REQUIRED FOR THE VOLTAGE ACROSS THE HEATER TO REACH 80% OF ITS RATED VOLTAGE AFTER APPLYING 4 TIMES RATED HEATER VOLTAGE TO A CIRCUIT CONSISTING OF THE TUBE HEATER IN SERIES WITH A RESISTANCE OF VALUE 3 TIMES THE NOMINAL HEATER OPERATING RESISTANCE.

## TYPICAL OPERATING CONDITIONS AND CHARACTERISTICS

CLASS A<sub>1</sub> AMPLIFIER - EACH UNIT

HEATER VOLTAGE	8.4	8.4	VOLTS
HEATER CURRENT	0.45	0.45	AMP.
PLATE VOLTAGE	90	250	VOLTS
GRID VOLTAGE	0	-8	VOLTS
PLATE CURRENT	10	9	MA.
AMPLIFICATION FACTOR	20	20	
PLATE RESISTANCE (APPROX.)	6 700	7 700	OHMS
TRANSCONDUCTANCE	3 000	2 600	μMHOS
PLATE CURRENT AT E <sub>c</sub> = -12.5 VOLTS	---	1.3	MA.
GRID VOLTAGE FOR I <sub>b</sub> = 10 μA. (APPROX.)	-7.0	-18	VOLTS

**SIMILAR TYPE REFERENCE:** Except for heater ratings, the 8SN7GTB is identical to the 6SN7GTB.

## TUNG-SOL

## RESISTANCE-COUPLED AMPLIFIER

$R_L$ MEG.	$R_{g1}$ MEG.	$R_B$ MEG.	$E_{bb} = 90$ VOLTS			$E_{bb} = 180$ VOLTS			$E_{bb} = 300$ VOLTS		
			$R_k$	GAIN	$E_o$	$R_k$	GAIN	$E_o$	$R_k$	GAIN	$E_o$
0.10	A	0.10	3300	14	13	2200	14	26	1800	14	40
0.10	A	0.24	3600	14	16	2700	15	33	2200	15	51
0.24	A	0.24	7500	14	16	5100	15	30	4300	15	44
0.24	A	0.51	9100	14	19	6800	15	39	5100	15	54
0.51	A	0.51	13000	14	16	9100	15	30	6800	16	40
0.51	A	1.0	15000	14	19	10000	16	32	7500	16	45
0.24	10	0.24	0	15	13	0	16	33	0	17	46
0.24	10	0.51	0	16	17	0	17	38	0	18	62
0.51	10	0.51	0	16	14	0	18	32	0	18	53
0.51	10	1.0	0	17	18	0	18	41	0	19	68

<sup>A</sup> VALUE OF  $R_{g1}$  IS NOT CRITICAL.

GAIN MEASURED AT  $E_o = 2.0$  VOLTS RMS OUTPUT.

$E_o$  IS RMS OUTPUT FOR 5% TOTAL HARMONIC DISTORTION.

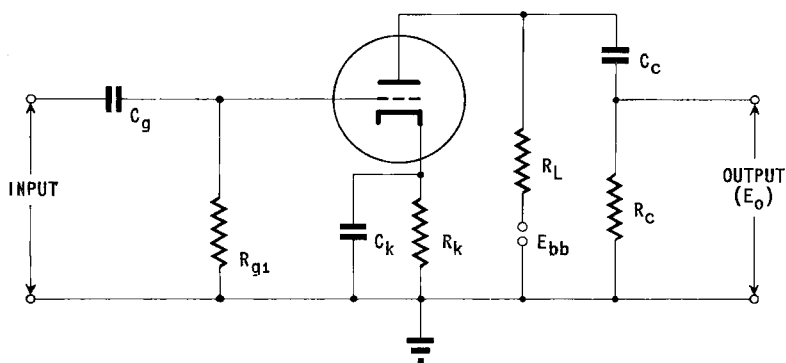

NOTE: COUPLING CAPACITORS  $C_g$  AND  $C_c$  SHOULD BE SELECTED TO GIVE DESIRED FREQUENCY RESPONSE.  $R_k$  SHOULD BE ADEQUATELY BY-PASSED BY CAPACITOR  $C_k$ .

# 8SN7GTB

