

ISS.	AMEND	DATE
1	1st DRAWN	29/11/05
2	FM1088C ADDED	24/01/06
3	UPDATED + RoHS	12/07/11

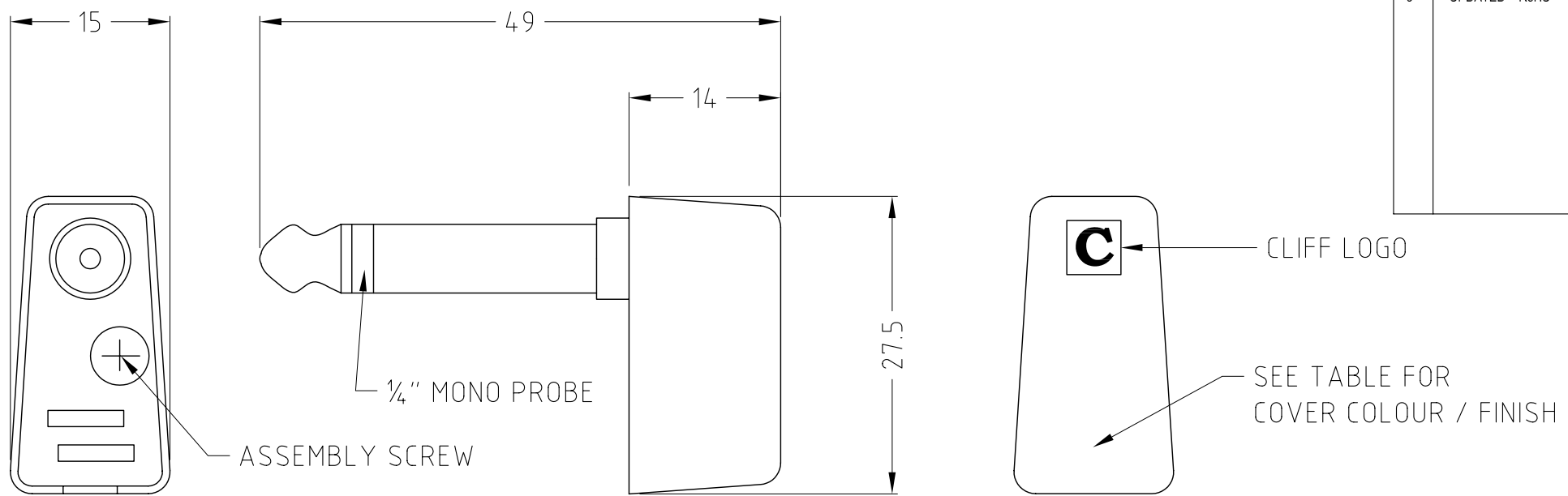

VARIANTS		
P/No.	COLOUR	TYPE
FM1095	BLACK	SEP/2C
FM1096	WHITE	SEP/2C
FM1088C	Ni PLATED	SEP/1C

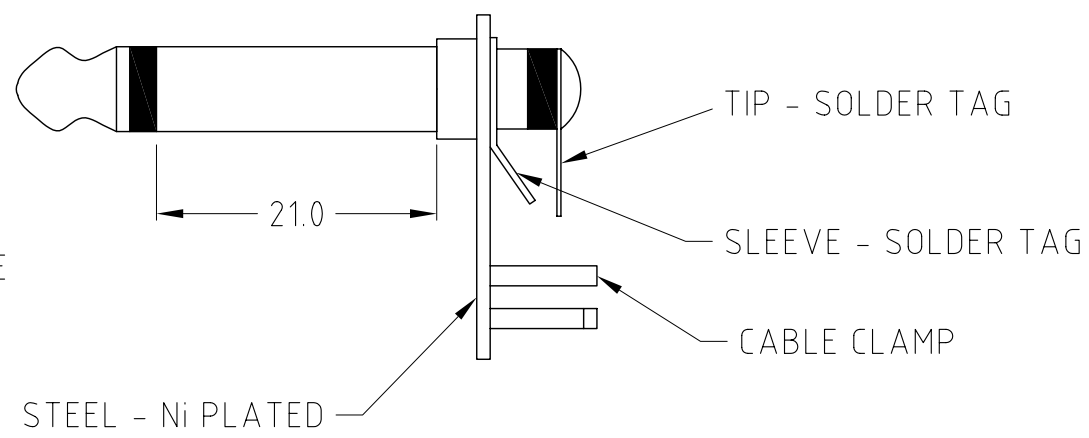

NOTE:
ALL VARIANTS HAVE
TWO SOLDER TAGS

RoHS COMPLIANT	
TOLERANCE	
NO DEC. PLACE ±	
1 DEC. PLACE ±	
2 DEC. PLACE ±	
HOLE Ø ±	
ANGLES ±	
UNLESS OTHERWISE STATED	
DO NOT SCALE	